

Инструкция по сборке

Модерн

Тумба ТВ

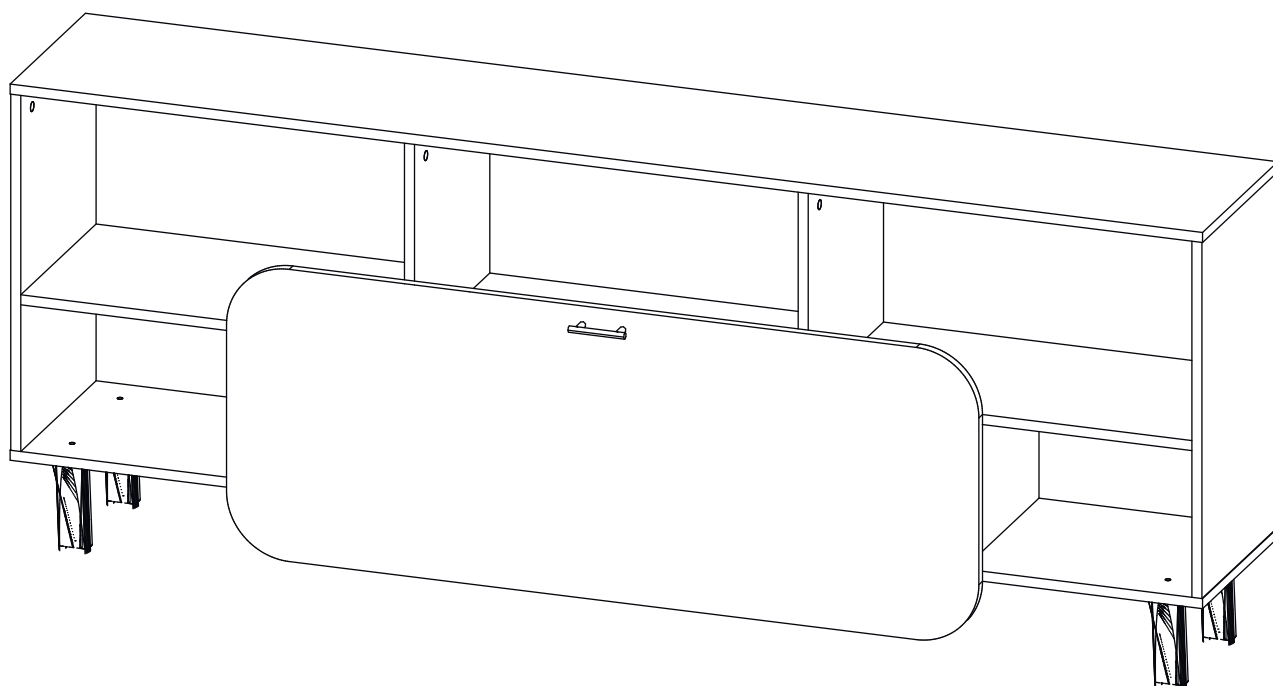



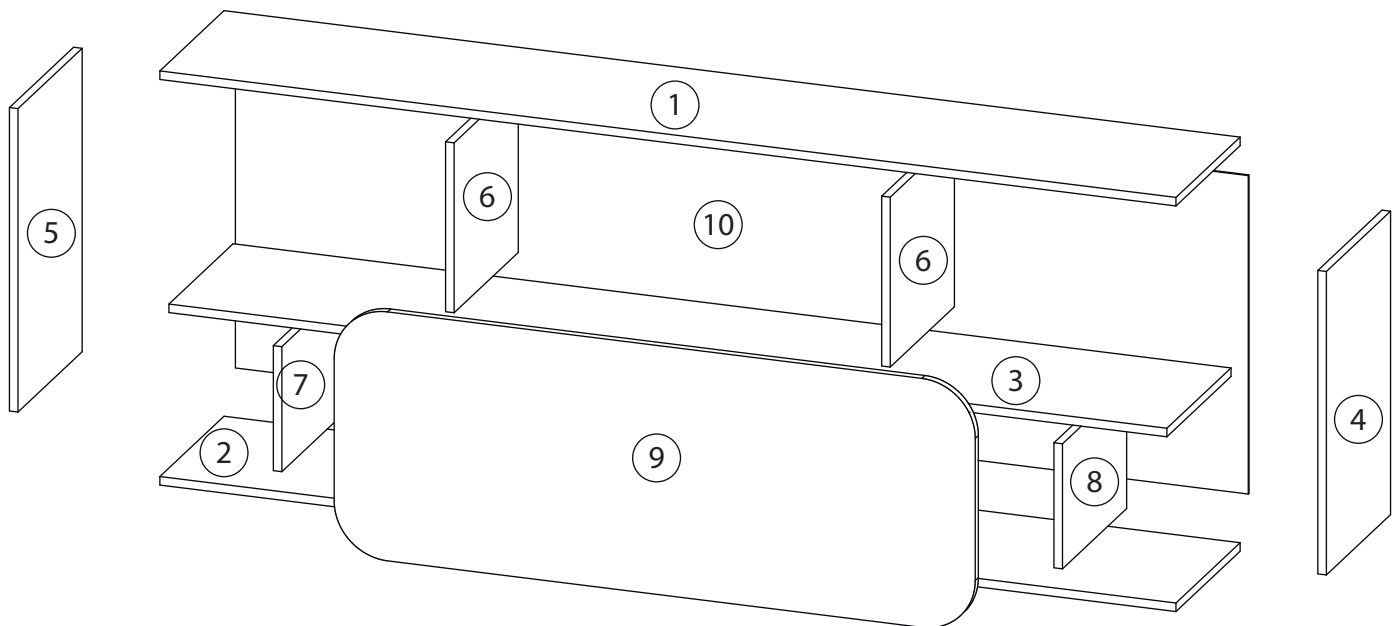

Детали

Поз.	Наименование	Кол-во	Длина	Ширина
1	Крыша	1	1902	330
2	Дно	1	1902	330
3	Полка	1	1868	330
4	Бок правый	1	568	330
5	Бок левый	1	568	330
6	Перегородка	2	318	330
7	Перегородка	1	234	330
8	Перегородка	1	234	330
9	Дверь1	1	1200	466
10	з/с	1	596	1896

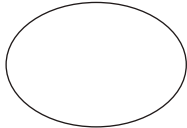

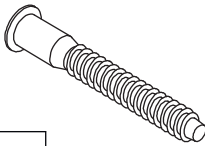
Фурнитура

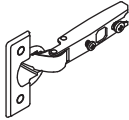
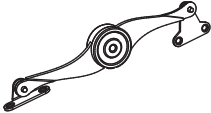
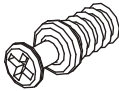
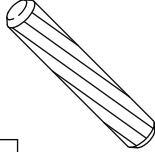
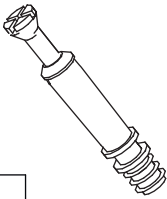
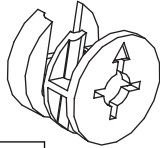
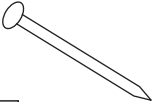
				
11	12	13	14	15
<u>Заглушка</u> $\varnothing 13$	<u>Заглушка</u> $\varnothing 17-20$	<u>Евровинт 6,3x13</u>	<u>Евровинт 7x50</u>	<u>Стяжка VB35</u>
				
16	17	18	19	20
<u>Саморез 3,5x16</u>	<u>Петля вкладная</u>	<u>Кронштейн</u> <u>механический</u>	<u>Винт для стяжки</u> <u>VB35</u>	<u>Шкант бук</u>
				
21	22	23		
<u>Шток эксцентрика</u>	<u>Эксцентрик</u>	<u>Гвоздь 1,6x25</u>		

1

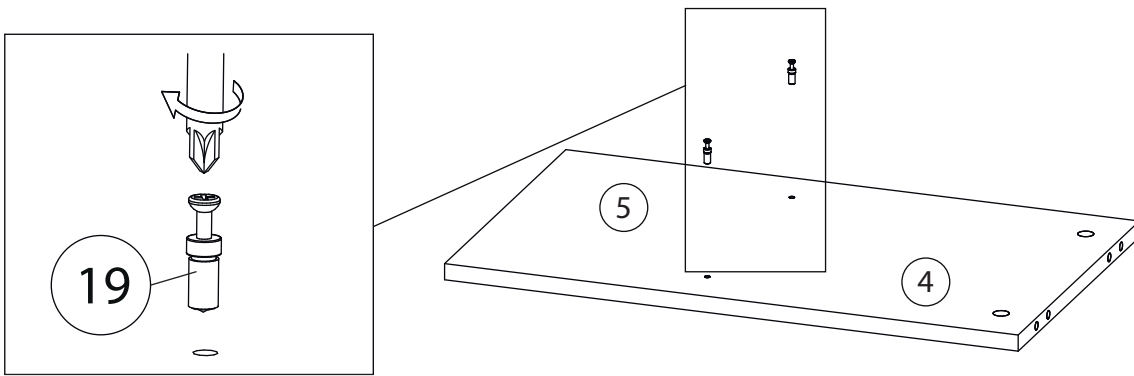

2

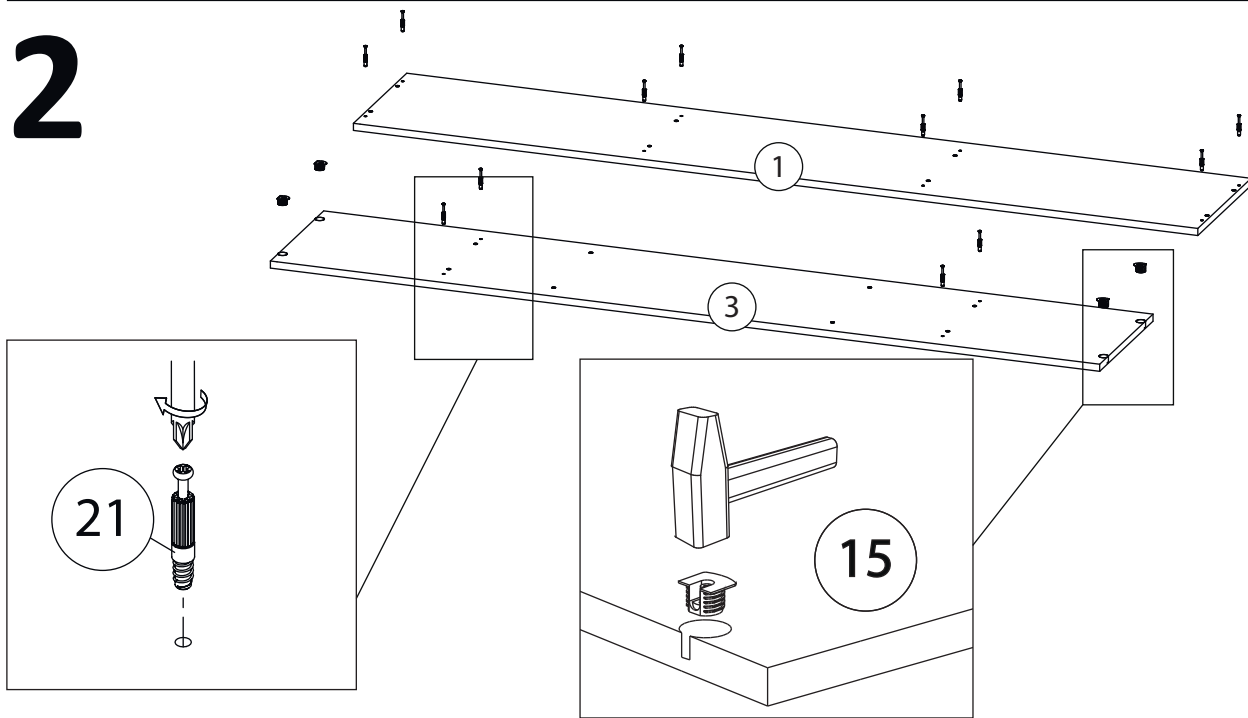

3

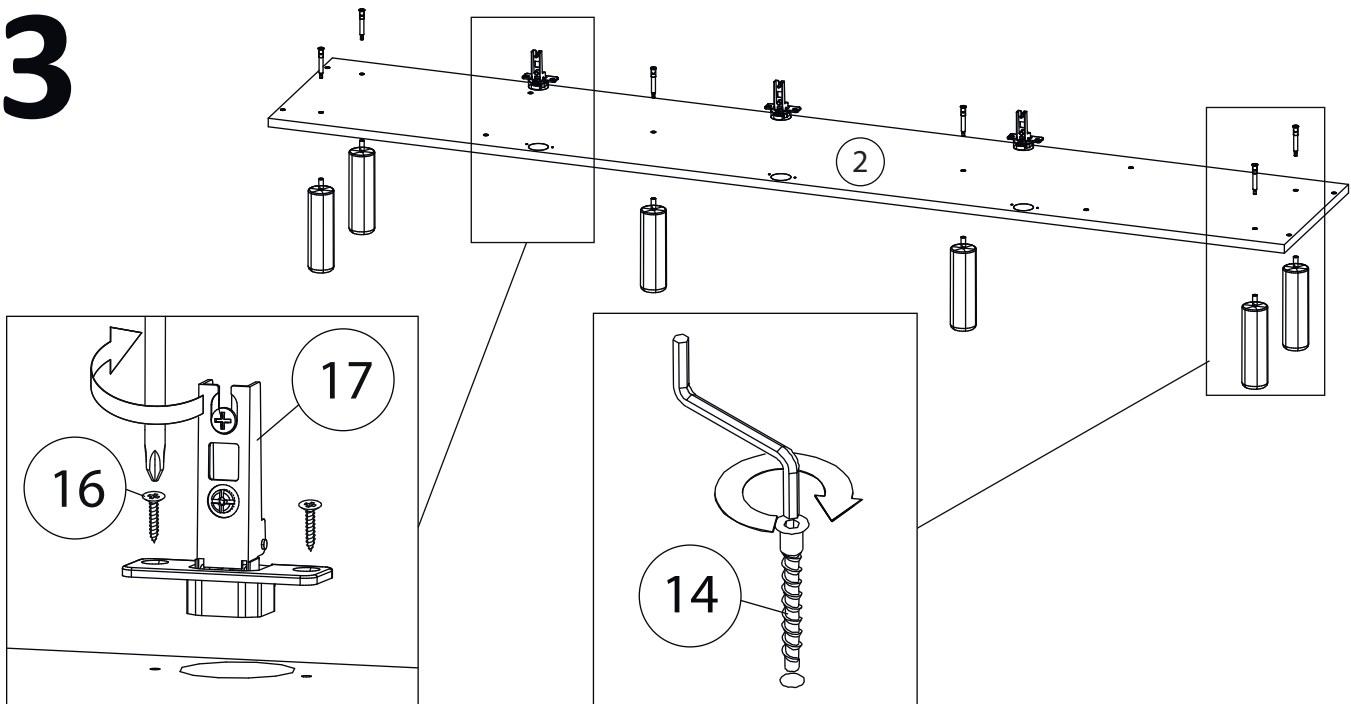

4

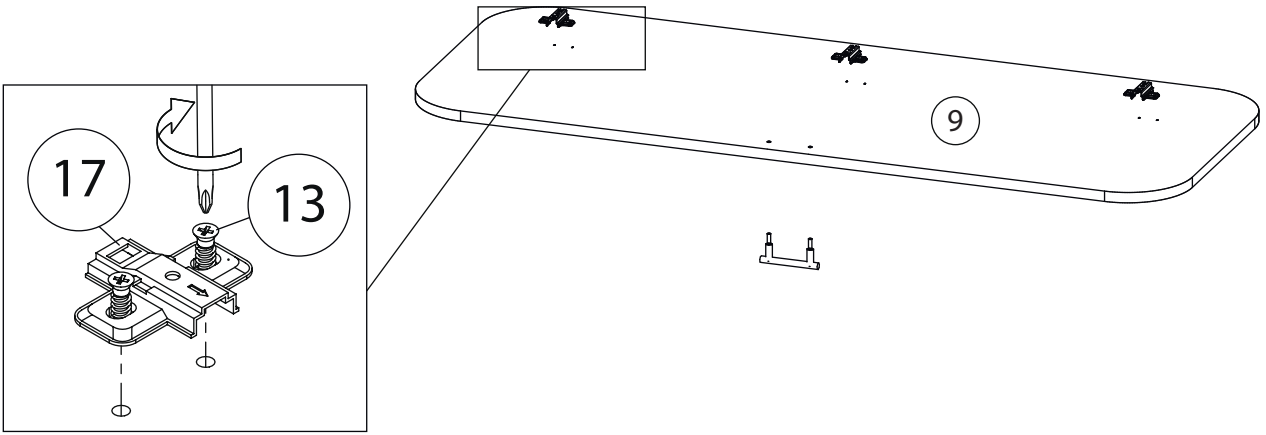

5

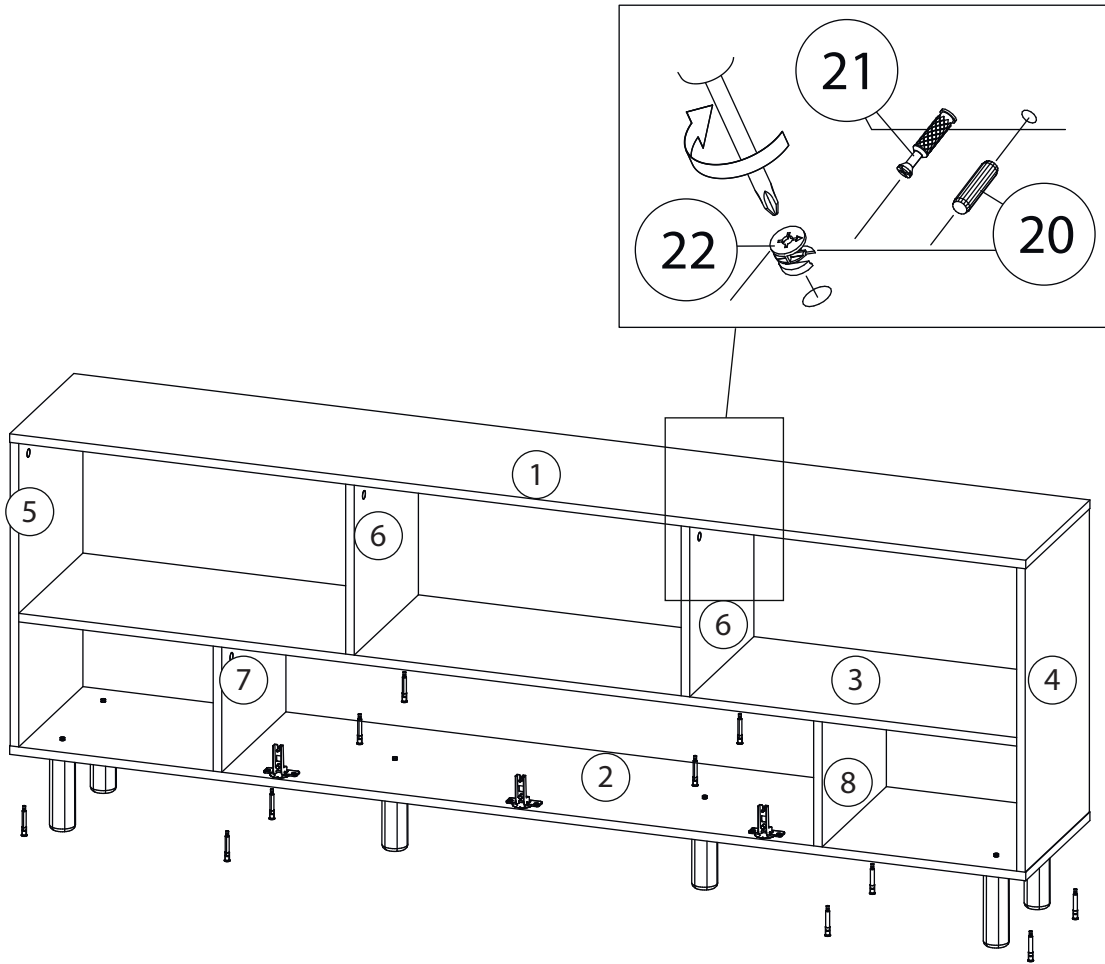

6

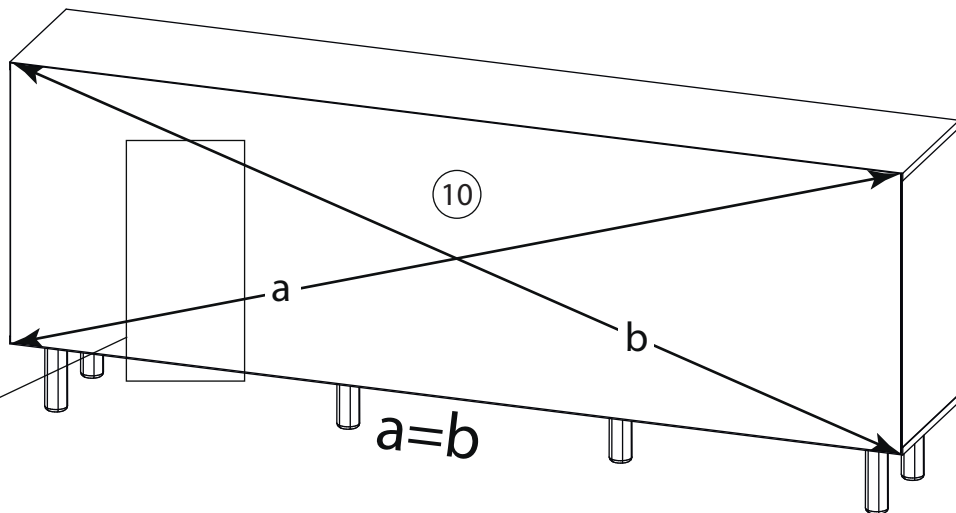
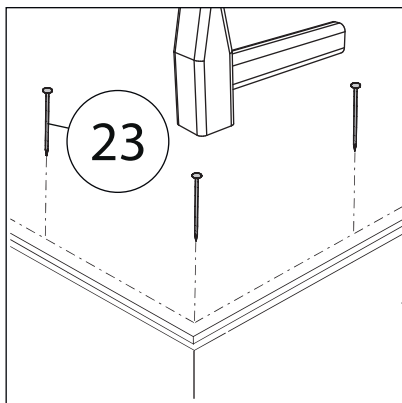

7

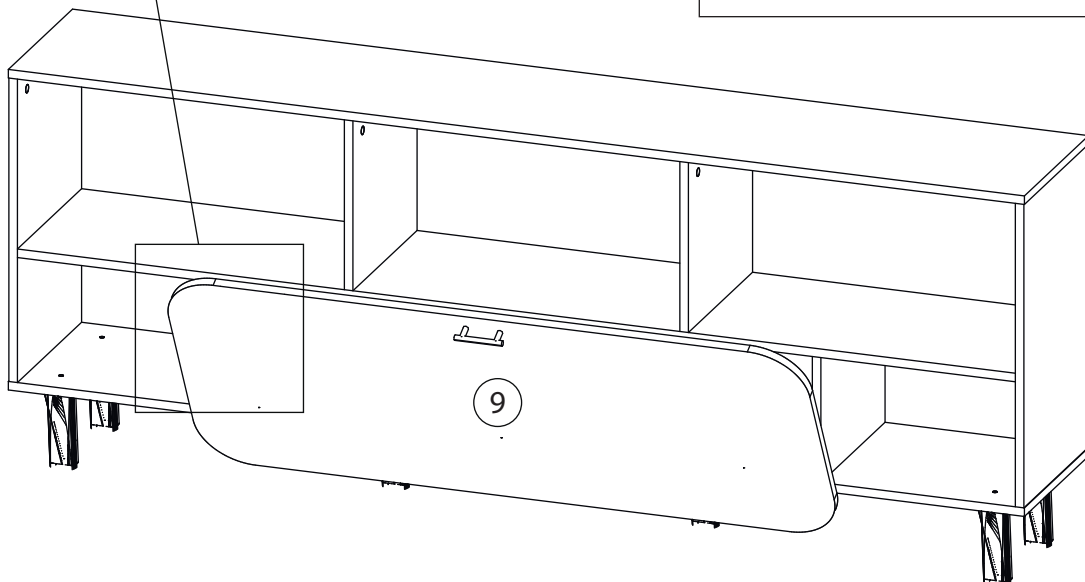
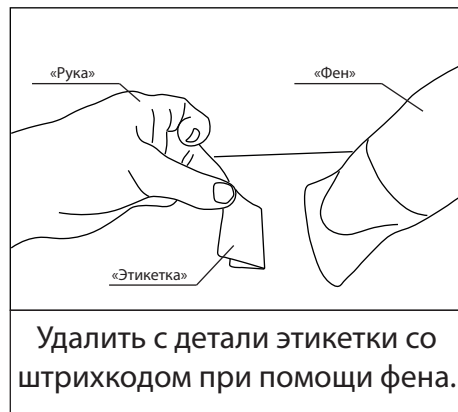
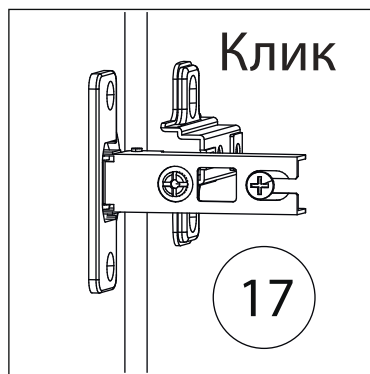
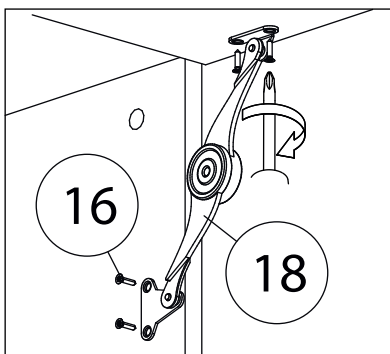

Заклеить технические отверстия заглушками.

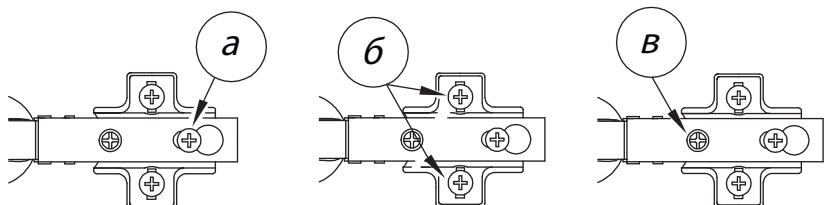

Регулировка петель
 а - регулировка расстояния между дверью и корпусом
 б - регулировка положения двери по-вертикали
 в - регулировка положения ТТдвери по-горизонтالي